



## The performance of a migrating corrosion inhibitor suitable for reinforced concrete

W. MORRIS, A. VICO and M. VÁZQUEZ\*

División Corrosión, INTEMA, Facultad de Ingeniería, Universidad Nacional de Mar del Plata, J.B. Justo 4302 B7608FDQ Mar del Plata, Argentina

(\*author for correspondence, fax: +54 223 4810046, e-mail: mvazquez@fi.mdp.edu.ar)

Received 19 November 2002; accepted in revised form 24 July 2003

*Key words:* chloride, corrosion, durability, inhibitors, reinforced concrete

### Abstract

The protection provided by a migrating corrosion inhibitor (MCI) based on an alkylaminoalcohol was tested on concrete specimens containing reinforcing steel bar (rebar) segments. Two inhibitor dosages were investigated, together with two water/cement ratios and various chloride contents. The inhibition efficiency was followed over a period of 1000 days measuring electrical and electrochemical parameters such as the corrosion potential, the corrosion current density, the electrical resistance and performing electrochemical impedance spectra. The inhibitor was able to reduce the corrosion rate only when the initial chloride content was below 0.16 wt.% (percent weight relative to cement content). The efficiency increased as the water/cement ratio increased. There was no beneficial effect when the initial chloride content was greater than 0.43 wt.%. The efficiency of the product increased when the amount of inhibitor being applied doubled.

### 1. Introduction

Among the many procedures that can be used to mitigate the corrosion of reinforcing steel in concrete, protective coatings and sealers, cathodic protection, concrete realkalization and corrosion inhibitors are the most commonly employed.

Over the last years the use of organic inhibitors has increased. Nowadays, this family of products is an alternative to the more commonly employed calcium nitrite-based inhibitors. Organic inhibitors offer protection by adsorbing and forming a protective film on the passive steel surface. The organic molecule usually contains a polar group that adsorbs on the metal and a non-polar, hydrophobic chain oriented perpendicular to this surface. On one hand these chains act by repelling aggressive contaminants dissolved in the pore solution and on the other, forming a tight film (barrier) on the metallic surface. On the basis of XPS measurements, Welle et al. [1] proposed a chemical model for the interaction between steel surfaces and formulations based on dilute solutions of a typical inhibiting agent (*N,N'*-dimethylaminoethanol). The organic molecule is apparently strongly bonded to the steel surface and displaces ionic species from the metal/solution interface hence protecting the surface film from ionic attack.

Corrosion inhibitors in reinforced concrete can be added to the mixing water during the concrete preparation or be applied to the external surface of hardened concrete. In this last case, the inhibiting compound

should diffuse through the concrete cover and reach the steel bar in a sufficiently high concentration to protect steel against corrosion. Those products acting under this principle are referred as migrating corrosion inhibitors (MCI).

The product under investigation is a commercial MCI based on an alkylaminoalcohol designed to protect steel against corrosive attack in reinforced concrete. It will be referred to as 'inhibitor' from here on.

Corrosion inhibitors designed to protect steel in concrete are frequently tested in synthetic pore solutions and in mortars. Studies carried out using concrete samples are scarce. Moreover, the results recently reported for inhibitors tested in the two simulated environments (pore solution and mortars) are somewhat contradictory [2–4]. Elsener et al. [2] studied the performance of an alkylamin-based inhibitor in mortars and in alkaline solutions. In mortars, there is no apparent pitting inhibition or corrosion rate decrease but the initiation of the corrosion process appears to be delayed. The beneficial effect decreases on carbonated mortars. In a recent publication by the same authors [3], the discrepancy between the fast diffusion of the MCI in mortar and the lack of corrosion inhibition was rationalised by the fact that only the diffusion of the volatile phase was measured. Migration of the non-volatile component (carbonic acids) through the solid was not proved and assumed to be slow. Thus, the inefficiency detected in mortars, as compared to solutions, should be related to the inability of the

non-volatile components to reach the metal. In turn, Hope and co-workers [4] assumed that the difference in the inhibitors efficiency tested in concrete or in synthetic pore solutions resulted from the dependence of the inhibition mechanism on chemical reactions within the cement phase.

In this context, the performance of the products in actual concrete structures can be difficult to estimate. So, in an attempt to better represent real service conditions observed on structures constructed on the seacoast of Argentina, the present investigation addresses the performance of a migrating inhibitor evaluating the commercial product under investigation in samples of steel embedded in concrete. Two inhibitor dosages were investigated, together with two water/cement ratios and various chloride contents.

## 2. Experimental

The complete description of the experimental set up can be found elsewhere [5]. Samples consisted of concrete specimens containing four steel reinforcement bar segments (rebars), as can be seen in Figure 1. The specimens had a cylindrical shape with a diameter of 15 cm and height of 20 cm. Rebars had a diameter of 1 cm and an exposed area of 40 cm<sup>2</sup>. They were placed in such a way that a concrete cover of 1.5 cm was achieved. Two of the four rebar segments in each specimen were coated and the performance of the coatings was analysed in a previous publication [6].

Four different concrete mixes were selected for this study. There were two types of concrete, a *standard quality* one prepared with a water/cement ratio (w/c) of 0.60 and a cement content of 300 kg m<sup>-3</sup>, and a *good quality* concrete prepared with w/c = 0.40 and a cement

content of 400 kg m<sup>-3</sup> were tested. Three different chloride contents were chosen in order to evaluate the influence of admixed chlorides on the inhibitor efficiency. This aspect was of great interest taking into account that in many coastal cities of Argentina concrete structures were built using sea sand as a fine aggregate. A concrete sample with no admixed chlorides was also prepared to be used as reference.

The compositions of the different concrete mixes are presented in Table 1. The initial chloride concentration in the concrete mixes ( $[Cl^-]_0$ ) was determined following the ASTM C1152 standard. Chloride concentration profiles resulting from exposure to the marine environment can be found in a previous publication [7].

A total of 24 specimens were prepared, six specimens per each concrete mix (A, B, C and D, see Table 1). They were demolded 24 h after casting and were kept in a laboratory environment (20 °C, 65% RH) for the following 6 days. Seven days after demolding, two different amounts of inhibitor were applied averaging  $480 \pm 10$  and  $830 \pm 10$  g m<sup>-2</sup> (later on referred to as 400 and 800 g m<sup>-2</sup>, respectively). The lower dose is the one recommended by the manufacturer. The six specimens prepared with each concrete mix were treated as follows: two were impregnated with 400 g m<sup>-2</sup> of inhibitor (labelled MI4, where M represents the mix composition, A, B, C or D), two with 800 g m<sup>-2</sup> (labelled MI8, where M represents the mix composition, A, B, C or D) and another two specimens were left as blanks with no inhibitor being applied. The product was applied on the external surface of hardened concrete following the manufacturer recommendations. The presence of the corrosion inhibitor at the rebar surface in a sufficient concentration was confirmed by analyses based on a colorimetric method proposed by the inhibitor's manufacturer.

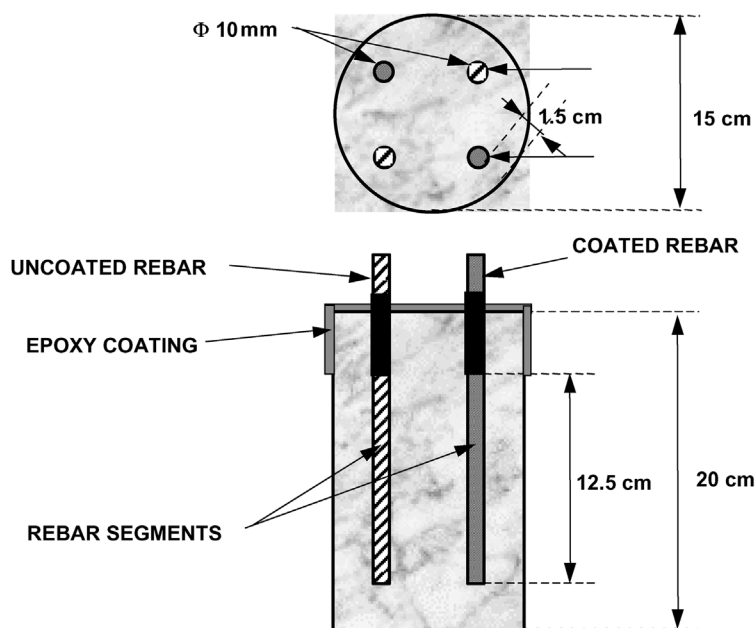

Fig. 1. Schematic representation of the cylindrical concrete test sample used in the study.

Table 1. Mix design composition

Mix design identification	A	B	C	D
Cement content/kg m <sup>-3</sup>	300	400	300	300
Water/l	180	160	180	180
Fine Aggregate (FA)				
River sand/kg	–	–	851	858
Sea sand/kg	858	789	–	–
River rock MAS = 10 mm/kg	1003	1042	1003	1003
Sodium chloride/kg	–	–	7.4	–
Superplasticizer/%	1.0	2.5	–	–
Water/cement ratio	0.60	0.40	0.60	0.60
Fine aggregate/total aggregate	0.46	0.43	0.46	0.46
% Cl <sup>-</sup> /wt. cement	0.78	0.43	1.60	0.16
Slump test/cm	3.0	3.0	6.5	8.0

The samples were kept for 90 days in an indoors environment. The specimens were then exposed to a so-called ‘seashore’ environment, located at approximately 100 m from the coastal line. Samples were directly exposed to rainfall, sea spray and wind. The environmental conditions in the city of Mar del Plata, Argentina (lat. S:37.56, long. W:57.35), are characterized by temperatures ranging from 14 to 27 °C during the summer and 3–13 °C during winter with an average monthly rainfall of 90 mm.

The corrosion progress was monitored over 1000 days following the variations of the main electrochemical parameters: the corrosion potential  $E_{\text{corr}}$ , the electrical resistance  $R$ , and the polarization resistance,  $R_p$ . This last parameter was used to estimate the rebar corrosion rate, CR.

The corrosion potential was measured using a high impedance voltmeter (HP E2378A) against a standard Cu/CuSO<sub>4</sub> saturated reference electrode (CSE). The electrical resistance ( $R_s$ ) was measured between the two uncoated rebar segments using a Nilsson 400 soil resistivity meter. This instrument uses a square wave of 97 Hz, preventing polarization of the electrodes. The electrical resistivity of concrete ( $\rho$ ) was calculated as  $\rho = kR_s$ , where  $k = 7.5$  [8]. Polarization resistance ( $R_p$ ) was evaluated as  $\Delta V/\Delta i$ , from potential sweeps up to  $\pm 0.01$  V from  $E_{\text{corr}}$  at a scan rate of  $10^{-4}$  V s<sup>-1</sup>. Experiments were performed using a CMS100 from Gamry Instruments Inc. potentiostat. A rebar segment was used as counter electrode and a CSE employed as reference electrode. The results were corrected to compensate the  $IR$  drop error.

Electrochemical impedance spectroscopy (EIS) tests were performed on all specimens treated with the inhibitor after approximately 800 days of exposure to the marine environment. The experimental set up was the same one used for the polarization resistance measurements. The a.c. signal had an amplitude of  $\pm 0.01$  V and the frequency was varied between 100 kHz and 0.1 mHz. Experiments were performed using a EIS900 unit from Gamry Instruments Inc. The analysis was performed with equivalent circuits using the Gamry software. Figure 2 shows the components involved on the equivalent circuit [9, 10]. Investigations performed in

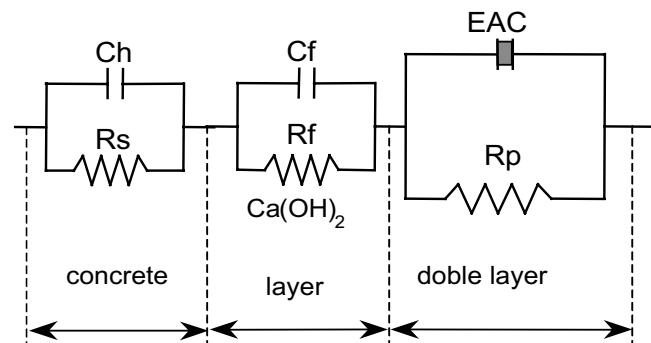

Fig. 2. Equivalent circuit proposed for modeling the electrochemical impedance response observed in the rebar segments embedded in concrete.

this field have suggested that a layer of precipitated Ca(OH)<sub>2</sub> covers the rebar surface providing an extra protection of steel from corrosion [11]. This film introduces a capacitance to the system that is identified as  $C_f$  in parallel with resistor  $R_f$ .  $C_h$  and  $R_h$  refer to the capacitor and resistor associated to concrete. Figure 3 shows the Nyquist diagram that could be expected from an EIS test performed on a concrete specimens.

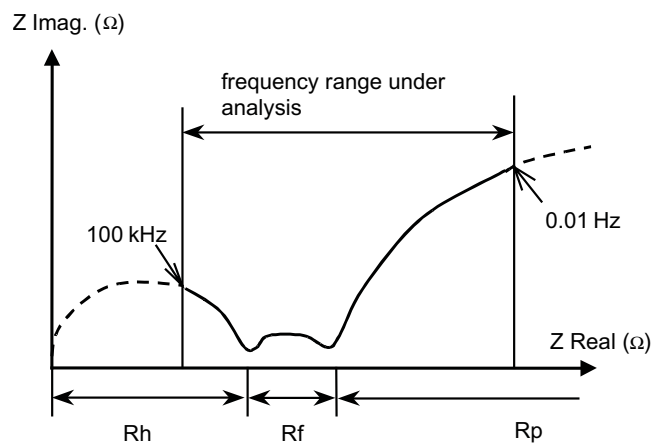

Fig. 3. Representation of a typical Nyquist diagram obtained for steel in concrete.

### 3. Results and discussion

Figure 4a and b present the variation of the rebar corrosion potential in time for the specimens (blank and treated with  $400 \text{ g m}^{-2}$  of inhibitor). Each value corresponds to the average of data read from four different rebars in two different concrete samples of the same composition. Dashed lines represent the threshold values commonly accepted to differentiate between active and passive rebar corrosion.  $E_{\text{corr}}$  values more positive than  $-0.2 \text{ V vs CSE}$  are generally representative of passive steel.  $E_{\text{corr}}$  values more negative than  $-0.35 \text{ V vs CSE}$  are usually considered typical of rebars undergoing active corrosion [12]. The blank and the treated specimens showed no significant difference between the rebar corrosion potential trends obtained on each of the three mixes containing admixed chlorides (A, B and C). The difference in the rebar corrosion potential trend of mix D ( $w/c = 0.6$  and no admixed chlorides) became evident after approximately 400 days of exposure. After this period of time, the  $E_{\text{corr}}$  values of the blank specimens start shifting negatively, probably due to the increase in chloride concentration at the rebar surface coming from the environment [7]. On the other hand, the rebar corrosion potential values of the equivalent treated specimens increase with time, reaching values characteristic of passive steel. Therefore, even when blank (D) and treated (DI4) specimens present similar chloride concentrations at the rebar surface, the pres-

ence of the inhibitor in mix DI4 seems to maintain the passive state of steel. The application of a higher amount of inhibitor showed no significant difference in the corrosion potential values.

Figure 5a and b present the variation in the resistivity for the blank and the specimens treated with  $400 \text{ g m}^{-2}$  of inhibitor respectively. After approximately 1000 days exposure to the seashore condition the treated specimens (DI4,  $w/c = 0.6$ , no admixed chlorides) give  $\rho$  values that are almost twice the corresponding values measured on the blank specimens. Preliminary investigations based on EIS indicate that both the increase in the electrical resistivity of the concrete and the presence of a protective layer on the rebar surface are responsible for the good performance of the inhibitor, when applied on concrete with no admixed chlorides (see below). A correspondence between  $\rho$  and  $\text{Cl}^-$  content in each mix was observed only on the treated specimens AI, CI and DI ( $w/c = 0.6$ ). The resistivity increased as the chloride concentration in these mixes decreased.

Figure 6 presents a comparison of the resistivity ( $\rho$ ) of concrete measured on the blank and treated specimens ( $400$  and  $800 \text{ g m}^{-2}$ ) corresponding to 180 and 360 days of exposure. The application of  $400 \text{ g m}^{-2}$  of inhibitor has little effect, both in time for the same concrete mix, and also when comparing blank and treated specimens. However, it is clear that the electrical resistivity of concrete increased (almost doubled) with time in all the samples treated with  $800 \text{ g m}^{-2}$ .

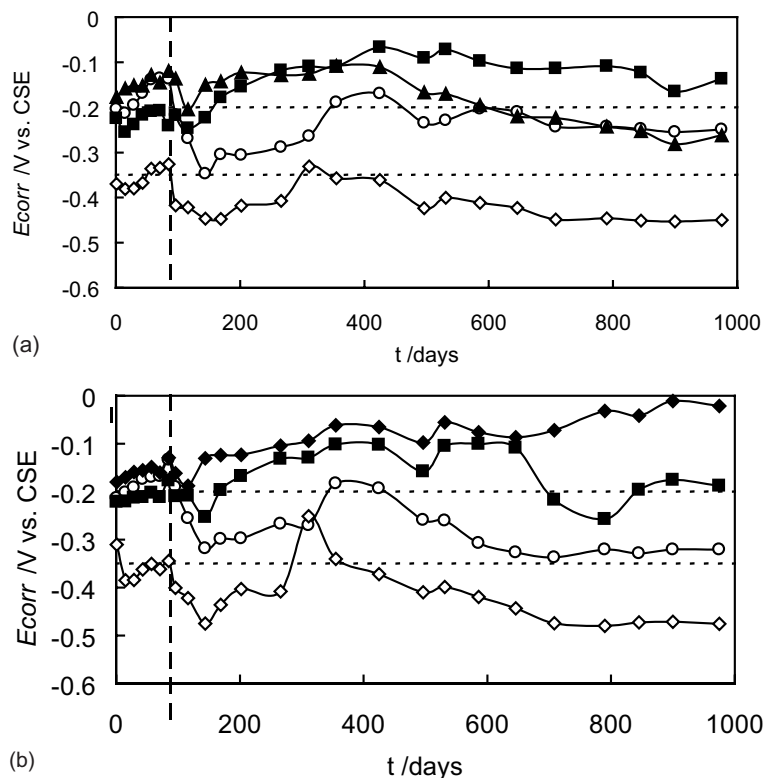

Fig. 4. Variation of the rebar corrosion potential ( $E_{\text{corr}}$ ) in time. The vertical line at 90 days indicates the time of exposure to the marine environment. (a) Blank specimens (○) A, (■) B, (◇) C, (▲) D; (b) specimens treated with  $400 \text{ g m}^{-2}$  of inhibitor (○) AI4, (■) BI4, (◇) CI4, (▲) DI4.

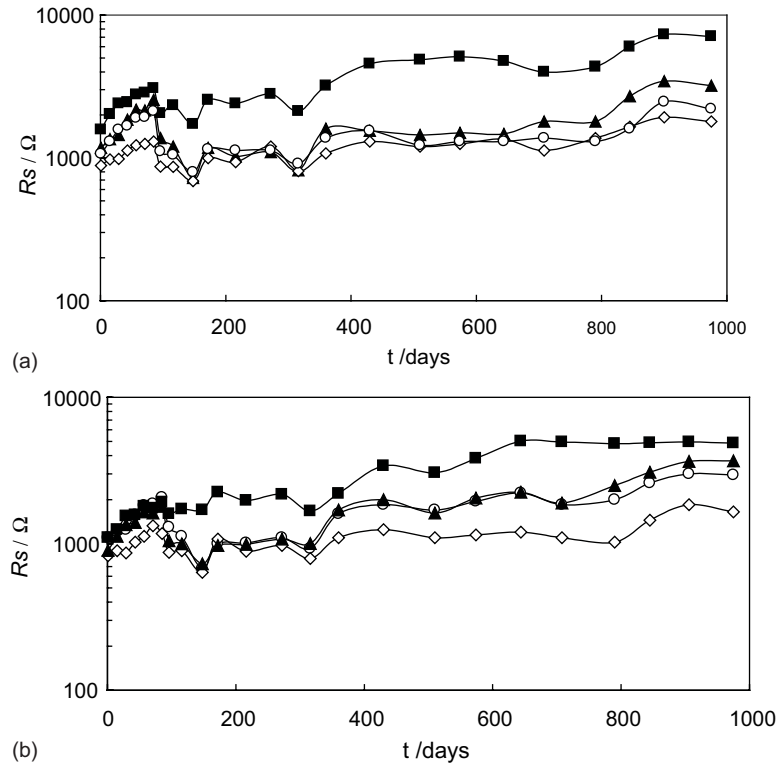

Fig. 5. Variation of concrete resistivity ( $\rho$ ) with time. The vertical line at 90 days indicates the time of exposure to the marine environment. (a) Blank specimens ( $\circ$ ) A, ( $\blacksquare$ ) B, ( $\diamond$ ) C, ( $\blacktriangle$ ) D; (b) specimens treated with  $400 \text{ g m}^{-2}$  of inhibitor ( $\circ$ ) AI4, ( $\blacksquare$ ) BI4, ( $\diamond$ ) CI4, ( $\blacktriangle$ ) DI4.

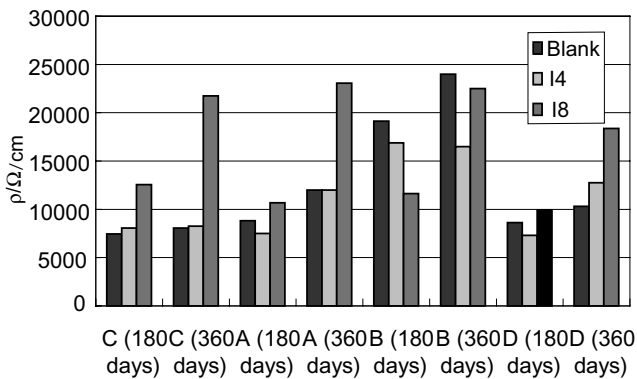

Fig. 6. Values of electrical resistivity of concrete measured on blank and treated with the inhibitor ( $400$  and  $800 \text{ g m}^{-2}$  after 180 and 360 days of exposure to the marine environment).

Figure 7a and b present the rebar corrosion rate (CR) trends for the blank specimens and for those treated with  $400 \text{ g m}^{-2}$  of inhibitor exposed to marine environment. No significant difference was observed between the CR values measured on blank and treated specimens prepared with admixed chlorides (compare A, B and C to AI4, BI4 and CI4). As expected, the rebar corrosion rate of both blank and treated specimens increased as the initial chloride content in these mixes increased. In samples with no admixed chlorides and  $w/c = 0.6$ , the treated specimens (DI4) gave CR values that were almost one order of magnitude lower than those measured on the blank specimens (D). Even accepting

some dispersion in the measured CR values, the decrease is significant. Only in the case of the DI4 specimens was it found that the measured CR fell clearly below  $1 \mu\text{m year}^{-1}$ , corresponding to rebars in the passive state.

Figure 8 compares the CR values measured on the blank and the treated specimens ( $400$  and  $800 \text{ g m}^{-2}$ ) corresponding to approximately 180 and 360 days of exposure to the marine environment. As presented above, the application of  $400 \text{ g m}^{-2}$  of inhibitor reduced the rebar corrosion rate only on specimens DI4. This effect was also observed on mixes CI8 ( $w/c = 0.6$ , FA = river sand with 1.5% admixed chlorides) and in a less extent on mix AI8 ( $w/c = 0.6$ , FA = sea sand) when the dosage of the product was doubled. Finally, the application of the corrosion inhibitor had no favorable effect on mix B ( $w/c = 0.4$ , FA = sea sand).

The results show that in the lower dose the inhibitor was only effective when applied on concrete with no admixed chlorides (initial  $[\text{Cl}^-] = 0.16\%$ ), having no beneficial effects in those mixes prepared with initial chloride contents higher than 0.43% by weight of cement. However, it should be taken into account that the chloride content at the rebar surface in samples D can increase up to 1% after 1000 days of exposure to the marine environment [7]. In concrete mixes prepared with high  $w/c$  ratios, the performance of the inhibitor improved as the amount of the product is increased by a factor of two.

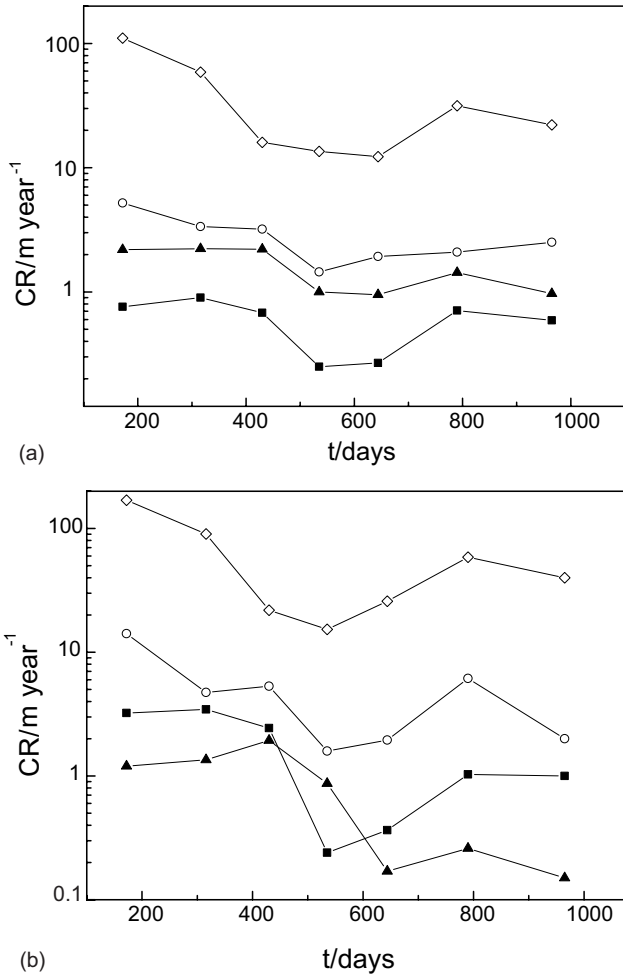

Fig. 7. Evolution of the rebar corrosion rate (CR) in time. (a) The blank specimens; (b) specimens treated with  $400 \text{ g m}^{-2}$  of inhibitor. All the specimens were exposed to the seashore environment at day 90.

Figures 9–11 present the Nyquist diagrams obtained for EIS tests on the rebar segments of the D, DI4 and DI8 specimens after 850 days of exposure. The plot

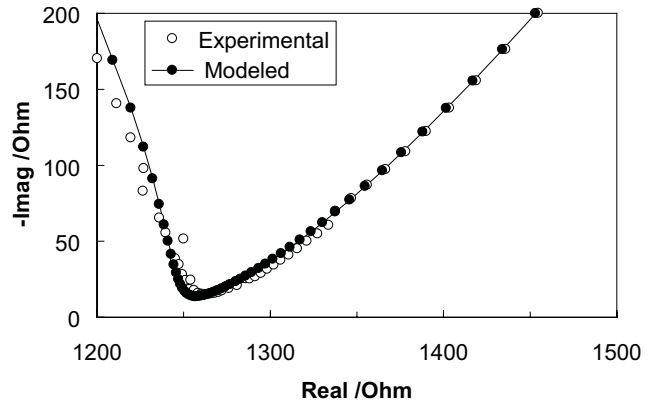

Fig. 9. Nyquist diagram corresponding to the rebar segment of specimen D (blank) after 850 days of exposure to the marine environment. Frequency range: 100 kHz to 0.01 Hz.

scales were adjusted in order to view the region of the curves where the time constant associated with any film or layer present on the rebar surface may be identified. Each plot presents the experimental and modelled data points. The values of  $R_s$  (concrete resistance),  $R_f$  (film resistance) and  $R_p$  (polarization resistance) were determined from these plots. These values are presented in Table 2 for the blank, treated with  $400 \text{ g m}^{-2}$  and with  $800 \text{ g m}^{-2}$  inhibitor specimens (D, DI4 and DI8, respectively).

Specimens DI4 and DI8 gave  $R_s$  values twice as high as that measured on the blank specimen. As  $R_s$  is proportional to the resistivity of concrete, the application of the inhibitor seems to increase the value of  $\rho$ , in good agreement with the results presented in Figure 6 for long exposure times.

One of the most important observations is that the film resistance  $R_f$  increases as the amount of inhibitor applied on the concrete surface increases. This behavior indicates that, in mix design D, the inhibitor improves

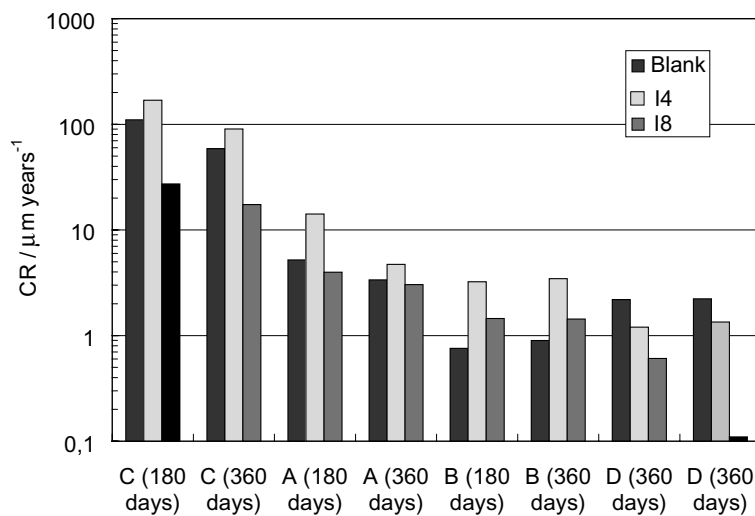

Fig. 8. Rebar corrosion rate (CR) values measured on the blank and treated with the inhibitor ( $400$  and  $800 \text{ g m}^{-2}$ ) after approximately 180 and 360 days of exposure to the marine environment.

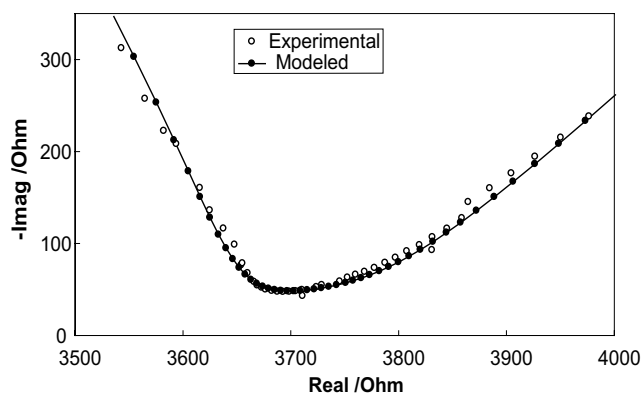

Fig. 10. Nyquist diagram corresponding to the rebar segment of specimen DI ( $400 \text{ g m}^{-2}$  inhibitor) after 850 days of exposure to the marine environment. Frequency range: 100 kHz to 0.01 Hz.

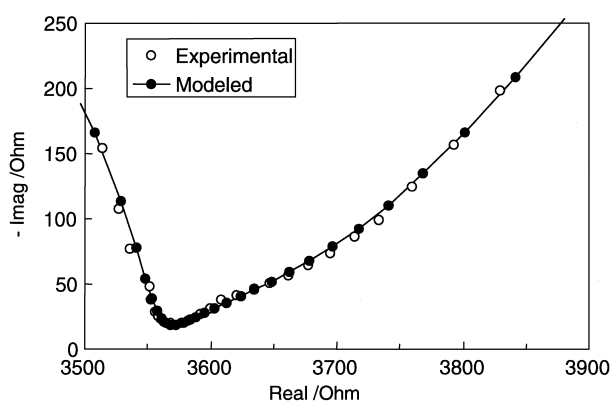

Fig. 11. Nyquist diagram obtained corresponding to the rebar segment of specimen DI ( $800 \text{ g m}^{-2}$  inhibitor) after 850 days of exposure to the marine environment. Frequency range: 100 kHz to 0.01 Hz.

Table 2. Values of  $R_s$  (concrete resistance),  $R_f$  (film resistance) and  $R_p$  (polarization resistance) obtained from the EIS measurements performed after 850 days of exposure to the marine environment (see Figures 10–12)

Specimen	$R_s$ / $\Omega$	$R_f$ / $\Omega$	$R_p$ / $\Omega$
D	1245	40	14 000
DI4	3670	150	35 000
DI8	3650	200	50 000

the formation of a protective film on the rebar surface. Finally, the highest values of  $R_p$ , and therefore the lowest rebar corrosion rate, are observed on specimens treated with  $800 \text{ g m}^{-2}$  inhibitor followed by specimens treated with  $400 \text{ g m}^{-2}$  (see Table 2). This observation agrees with the results shown above where the lowest rebar corrosion rates were observed on the specimens treated with  $800 \text{ g m}^{-2}$  followed by those treated with  $400 \text{ g m}^{-2}$  and finally the blank specimens (see Figure 8).

#### 4. Conclusions

The efficiency of the corrosion inhibitor depends on the initial chloride concentration in the concrete ( $[\text{Cl}^-]_0$ ). The product helps to decrease the rebar corrosion rate in concrete that presents values of  $[\text{Cl}^-]_0$  lower than 0.43% (by weight) with respect to the cement content.

The performance of the corrosion inhibitor depends on the quality of concrete, being more effective on concrete mixes prepared with high water to cement ratios. As the penetration of the product takes place within the gaseous phase of the concrete pores, the higher the porosity, the easier the product penetrates the concrete cover.

The efficiency of the product increases with the application of higher doses. The application of  $400 \text{ g m}^{-2}$  showed positive effects (reduction of rebar corrosion rate) only in concrete mix D which was prepared with river sand, no admixed chlorides and  $w/c = 0.6$ . On the other hand, the application of  $800 \text{ g m}^{-2}$  showed positive effects on all the concrete mixes examined with the exception of mix B, prepared with  $w/c = 0.4$ .

On the basis of EIS results, the rebar corrosion rate reduction observed on the specimens treated with inhibitor could be attributed to the consolidation of the protective passive film that naturally appears on the steel surface in contact with concrete having high alkalinity and no chlorides.

#### References

1. J.D. Welle, K. Liao, M. Kaiser, U. Grunze, Mader and N. Blank, *Appl. Surf. Sci.* **119** (1997) 185.
2. B. Elsener, M. Buchler, F. Stalder and H. Bohni, *Corrosion* **55** (1999) 1155.
3. B. Elsener, M. Buchler, F. Stalder and H. Bohni, *Corrosion* **56** (2000) 727.
4. L. Mammoliti, C.M. Hansson and B.B. Hope, *Cement Concrete Res.* **29** (1999) 1583.
5. W. Morris and M. Vázquez, *Cement Concrete Res.* **32** (2002) 259.
6. W. Morris, M. Vazquez and S. Rosso, *J. Mater. Sci.* **35** (2000) 1885.
7. W. Morris, A. Vico, M. Vazquez and S.R. de Sanchez, *Corros. Sci.* **44** (2002) 81–99.
8. W. Morris, A. Sagues and E. Moreno, *Cement Concrete Res.* **26** (1996) 1779.
9. L. Lemoine, F. Wenger and J. Galland, in N.S. Backer, V. Chaker and D. Witiñj (Eds), 'Corrosion Rates of Steel in Concrete', ASTM STP 1065, (ASTM, Philadelphia, 1990), p. 118.
10. D.G. John and P.C. Searson, and J.L. Dawson, *Br. Corros. J.* **16** (1981) 102.
11. C.L. Page, *Nature* **258** (1975) 5335.
12. ASTM C 876, 'Standard Test Method for Half-Cell Potential for Uncoated Reinforcing Steel in Concrete' (American Society of Testing and Materials, Philadelphia, 1987).